

## Data Sheet

# 81 Bolt-thru Isolation Ring

### FEATURES

- 360° Instrument rotation with SQR™ option
- Selection of 1" through 10" nominal pipe size
- Non-clogging/low maintenance
- Complete instrument protection
- Ensure reliable/accurate pressure readings
- Optional retrofit end plates to replace competitive units

### TYPICAL USES

- Water and Wastewater
- Mining

### SPECIFICATIONS

Sizes:	1" to 10"
Process Connection Size:	¼ NPT Female, ½ NPT Female
Pressure Rating (MAWP):	Per customer flanges: ASME B16.5 150 or 300 Class Pressures
Fill:	Glycerin: 0°F to 400°F (-18°C to 204°C) Silicone (10Cst): -40°F to 500°F (-40°C to 260°C) Silicone (50Cst): -40°F to 600°F (-40°C to 316°C) Halocarbon®: -70°F to 300°F (-57°C to 149°C)
Instrument Removal:	Direct-mount, Needle valve, Safe Quick Release (SQR™), Needle valve and SQR™ (02T conn.)
Added Tolerance:	±0.5% typical
Approvals:	CRN

### WETTED COMPONENTS

End Plate Material	Flexible Liner
Carbon steel, 316L SS, PVDF	Buna, PTFE, EPDM, Natural rubber, and Viton®

### NON-WETTED COMPONENTS

Body
Carbon Steel, 316Stainless steel

### MIN/MAX TEMPERATURE LIMITS

Liner	Temperature Limits
Buna-N	-30°F to 225°F (-34°C to 107°C)
Teflon	-15°F to 350°F (-25°C to 177°C)
Viton	-15°F to 350°F (-25°C to 177°C)
Natural Rubber	-30°F to 225°F (-34°C to 107°C)
EPDM	-40°F to 300°F (-40°C to 149°C)



### 81 Bolt-thru Isolation Ring

Nominal Size: 1" to 10"

### KEY BENEFITS

- Reliable when continuous pressure measurements are needed
- Non-clogging and low maintenance
- Complete instrument protection

# Data Sheet

## 81 Bolt-thru Isolation Ring

ORDERING CODE	Example:	81	02	E	B	B	02T	N	300	XCK	H3	NH
<b>Seal Type</b>												
81 - Bolt-thru isolation ring		81										
<b>Process Connection Size</b>												
02 - 2" (see table 2 on page 3)			02									
<b>Inner Flexible Wall</b>												
E - Buna-N				E								
T - PTFE (available in 1" to 10")												
Y - Viton®												
R - Natural rubber												
P - EPDM												
<b>End Plate Material</b>												
B - Carbon steel					B							
S - 316L Stainless steel												
K - CPVC (available in 1")												
F - PVDF												
<b>Body Material</b>												
B - Carbon steel						B						
S - 316L Stainless steel												
<b>Instrument Connection Size</b>												
02T - ¼ NPT Female							02T					
04T - ½ NPT Female (ring body tapped with ¼ NPT connection; 04T connection utilizes ¼-½ NPT adapter)												
<b>Instrument Removal Option</b>												
N - Direct-mount								N				
V - Needle valve												
Q - Safe Quick Release (SQR™)												
Z - Needle valve and SQR (requires 02T instrument connection)												
<b>Pressure Class</b>												
150 - 150-class ASME												
300 - 300-class ASME									300			
<b>Options</b> (if choosing option(s) must include an "X")												
Fill Fluid (see table 3 on page 3 for more available fill fluids)										X__		
CG - Glycerin												
CK - Silicone 50cSt										CK		
CF - Halocarbon®												
CT - 50/50 Ethylene Glycol/water												
<b>Multiple Instrument Assemblies</b> (contact factory for additional arrangements or custom orientations.)												
H3 - ¼ NPT gauge/ ¼ NPT Male transducer/ 02T isolation ring											H3	
H5 - ½ NPT gauge/ ½ NPT Male switch/ 04T isolation ring												
H6 - ½ NPT gauge/ 2 ½ NPT Male switches/ 02T isolation ring												
H7 - ¼ NPT gauge/ ¼ NPT Female switch/ 02T isolation ring												
<b>Optional Features</b>												
IR - Retrofit end plates (custom end plates widths for drop-in replacements)												
NH - Stainless steel tag wired to ring												NH
Q8 - Elbow for vertical pipe installation (02T connection only)												

Consult factory for multiple instrument assemblies, welded assembly options, additional process connection sizes and fill fluids

# Data Sheet

## 81 Bolt-thru Isolation Ring

**TABLE 2 – PROCESS CONNECTION TABLE**

Process Connection Code (Nominal Size)	Type 81 (Ordering Code)
1"	01
2"	02
3"	03
4"	04
5"	05
6"	06
8"	08
10"	10

Consult factory for larger sizes

**TABLE 3 – FILL FLUID TABLE**

Fill Fluid	Temperature Range	Code
Glycerin	0°F to 400°F (-18°C to 204°C)	CG
Silicone 10cSt	-40°F to 500°F (-40°C to 260°C)	DJ
Silicone 50cSt	-40°F to 500°F (-40°C to 260°C)	CK
Halocarbon®	-80°F to 390°F (60°C to 200°C)	CF
50/50 Ethylene Glycol/Water	-25°F to 190°F (-32°C to 88°C)	CT

### DIMENSIONS in inches

For reference only, consult Ashcroft for specific dimensional drawings

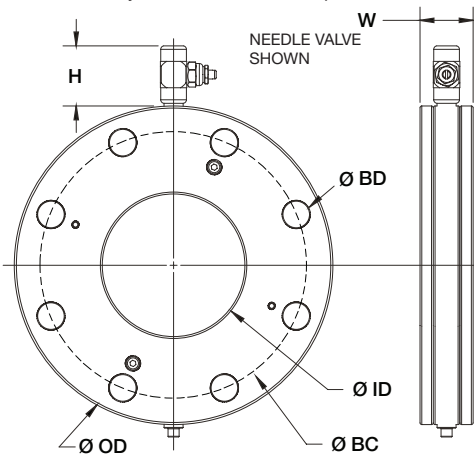

ANSI ASME Class	Nom. Pipe Size	Inner Dia. (ID)	Outer Dia. (OD)	Width (W)	Bolt Circle (BC)	Bolt Dia. (BD)	No. Of Bolt Holes	Instrument Removal (H)			Weight Lbs.
								Direct	Safe Quick Release	Needle Valve	
150	1" SS/CS	1.05	4.25	2.00	3.12	0.625	4	0	2.04	1.70	5.7
	1" CPVC	1.05	4.25	2.25	3.12	0.625	4	0	2.04	1.70	4.0
	1.5" SS/CS	1.61	5.00	2.00	3.88	0.625	4	0	2.04	1.70	7.9
	1.5" CPVC	1.61	5.00	2.25	3.88	0.625	4	0	2.04	1.70	5.6
	2"	2.07	6.00	2.00	4.75	0.75	4	0	2.04	1.70	12.0
	3"	3.07	7.50	2.00	6.00	0.75	4	0	2.04	1.70	18.4
	4"	4.03	9.00	1.50	7.50	0.75	8	0	2.04	1.70	18.6
	5"	5.05	10.00	1.50	8.50	0.88	8	0	2.04	1.70	21.0
	6"	6.07	11.00	1.50	9.50	0.88	8	0	2.04	1.70	23.9
	8"	7.98	13.50	1.50	11.75	0.88	8	0	2.04	1.70	34.5
10"	10.02	16.00	1.50	14.25	1.00	12	0	2.04	1.70	44.5	
300	2"	2.07	6.50	2.00	5.00	0.75	8	0	2.04	1.70	13.8
	3"	3.07	8.25	2.00	6.62	0.88	8	0	2.04	1.70	22.0
	4"	4.03	10.00	1.50	7.88	0.88	8	0	2.04	1.70	24.5
	5"	5.05	11.00	1.50	9.25	0.88	8	0	2.04	1.70	32.0
	6"	6.07	12.50	1.50	10.62	0.88	12	0	2.04	1.70	34.9
	8"	7.98	15.00	1.50	13.00	1.00	12	0	2.04	1.70	47.1
	10"	10.02	17.50	1.50	15.25	1.13	16	0	2.04	1.70	58.8